

## Weight Transmitter and Control Device



# SC991W

### Device Features

- 2 line 16 Character LCD Display
- 5 pcs LED Indicator
- 1 pcs 1-3mV/V Max.4 pcs 350 Ω Load Cell-Connection Possibility
- 4 pcs NO Relay or 24V Logic Output
- 2 pcs Analog Output (0/4-20mA and 0/2-10V)
- 16Bit A/D Resolution for Weight Measured
- 16Bit Resolution for Speed Measured
- 1 pcs RS485 Modbus RTU Communication Unit
- 100-240Vac/dc or 10-32Vac/dc Supply Voltage

SC991W series devices are devices used to measure weight. There is an LCD display and 5 keys on the front panel to perform operations such as taring and calibration. There are two analog outputs and one RS485 Modbus RTU to transfer the measured weight information to another scale system. Four relay outputs can be used for ON / OFF control and alarm.

5

### Device Dimensions

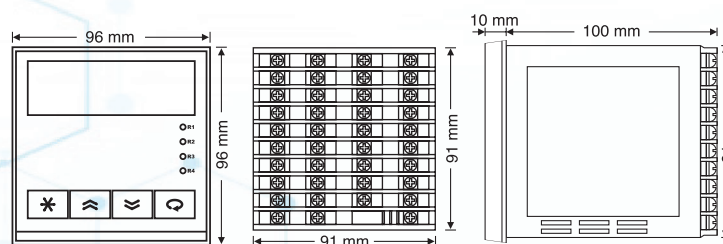

Dimensions for Panel Cutting =  $92 \pm 0,5$  mm x  $92 \pm 0,5$  mm

## Technical Specifications

<b>Power Supply</b>	100-240Vac/dc +%10, -%15 24Vac/dc +%10, -%20
<b>Power Consumption</b>	6W, 10VA
<b>Screen</b>	2 x 6 Digit LCD Screen
<b>Load Cell Input</b>	1-3mV/V Max. 4 pcs 350 Ω load cell
<b>Load Cell Feeding</b>	8V +/- %0,25V
<b>Analog Outputs (O1,O2)</b>	Current : 0/4-20mA ( RL≤500Ω ) Volatge : 0/2-10V ( RL≥1MΩ )
<b>Relay Outputs (R1,R2,R3)</b>	Contact : 250Vac 10A NO Pulse : 24Vdc 20mA
<b>Contact Lifetime</b>	No load : 10,000,000 switching 250V 5A at Resistive Load : 100,000 switching
<b>Memory</b>	100 Years, 1000.000 Renewable
<b>Accuracy</b>	+/-% 0,2
<b>Environment Temperature</b>	Working : -20.....+50 C
<b>Dimensions</b>	Width = 96 mm Height = 96 mm Depth = 110 mm
<b>Panel Cutting Dimensions</b>	91 +/-0,5 mm x 91 +/-0,5 mm
<b>Weight</b>	430

## Modular Structure and Connection Diagram

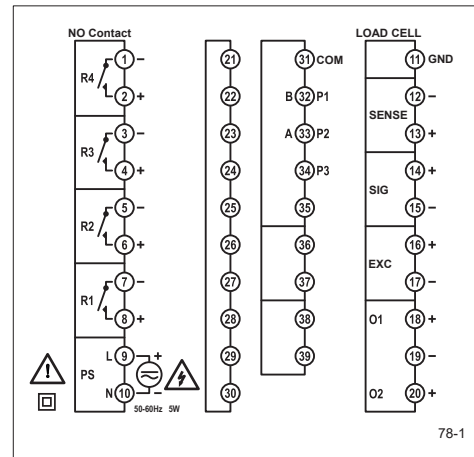

## Product Code

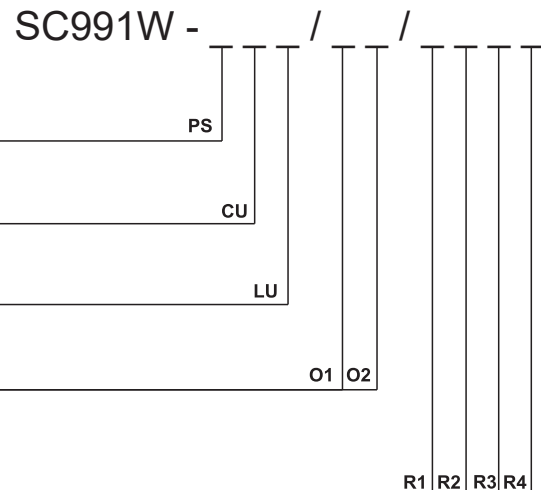

**Supply Voltage :** \_\_\_\_\_ PS  
0 = 100-240Vac (Universal)  
1 = 24Vac/dc

**Communication Module :** \_\_\_\_\_ CU  
0 = N/A  
3 = RS485 Communication Unit

**Logic Input Module :** \_\_\_\_\_ LU  
0 = N/A  
1 = 3 Pcs 15 V Logic Input

**Analog Output Module :** \_\_\_\_\_ O1 O2  
0 = N/A  
1 = 0/4-20mA Current Output  
2 = 0/2-10Vdc Voltage Output

**R1,R2,R3,R4 Output Modules :** \_\_\_\_\_ R1 R2 R3 R4  
0 = N/A  
1 = NO Contact  
2 = 24V Logic Output (For SSR Driving)

5