

Programmable Process Indicator



PI94

PI94 devices are devices that can be configured as fully modular and each module is self-contained, designed to measure many process variables in industrial settings and to transmit the measured values to other units. Compliance with international standards, reliability and ease of use were taken during the design phase. For this reason, they are ergonomic devices that can be used for many different controls in many sectors.

Device Features

- 1 pcs 4 Digit Numeric Display
- 1 pcs Transmitter Supply Output (24VDC)
- 1 pcs Universal Sensor Input (TC, RT, mA, mV, V)
- 1 pcs Analog Output (0/4-20mA, 0/2-10V)
- 1 pcs RS485 Communication Unit
- 100-240V AC/DC Universal or 24V AC/DC Supply Voltage
- Isolation between Input/Output modules

- Sensor Error Detection
- 100ms Sampling and Control Cycle
- Standard MODBUS RTU communication protocol
- Configuration via Computer

Input Types

Sensor Type	Standard	Min.	Max.
Type-T (Cu-Const)	IEC60584	-200 °C	300 °C
Type-U (Cu-Const)	IEC60584	-200 °C	600 °C
Type-J (Fe-Const)	IEC60584	-200 °C	800 °C
Type-L (Fe-Const)	IEC60584	-200 °C	900 °C
Type-K (NiCr-Ni)	IEC60584	-200 °C	1200 °C
Type-E (Cr-Const)	IEC60584	-200 °C	1200 °C
Type-N (Nicrosil-Nisil)	IEC60584	0 °C	1200 °C
Type-S (Pt%10Rh-Pt)	IEC60584	0 °C	1500 °C
Type-R (Pt%13Rh-Pt)	IEC60584	0 °C	1600 °C
Type-B (Pt%18Rh-Pt)	IEC60584	0 °C	1800 °C
Pt-100	DIN 43760	-200 °C	850 °C
0 / 4-20 mA		0 mA	20 mA
0 / 2-10 VDC		0 VDC	10 VDC

Device Dimensions

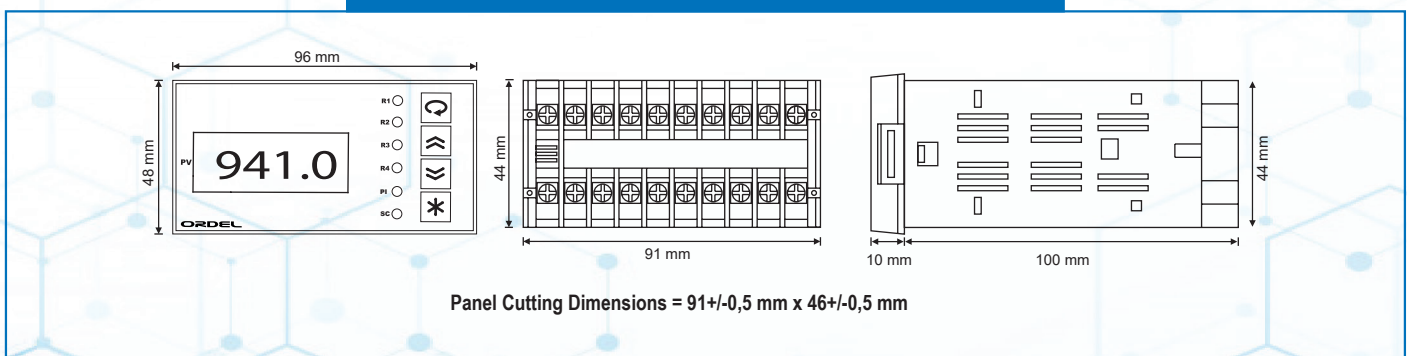

Technical Specifications

Power Supply (PS)	100-240 Vac/dc +10%-15% 24 Vac/dc +10%-20%
Power Consumption	6W, 10VA
Universal Sensor Input (S1)	Thermocouple = B , E, J, K, L, N, R, S, T, U Two Wired Transmitter = 4-20mA Resistance Thermometer = Pt-100 Current = 0/4-20mA Voltage = 0-50mV, 0/2-10V
Transmitter Supply (TX)	24Vdc (I _{sc} = 30mA)
Analog Input Impedance	Thermocouple, mV = 10MΩ Current = 10Ω Voltage = 1MΩ
Analog Output (O1)	Current = 0/4-20mA (R _L ≥500Ω) Voltage = 0/2-10V (R _L ≥1MΩ)
Memory	100 Years, 100.000 Renewals
Accuracy	+/- 0,2%
Sampling Time	100 ms
Environment Temperature	Working = -10...+55°C Storage = -20...+65°C
Protection Class	Front Panel = IP54 Trunk = IP20
Dimensions	Width = 96 mm Height = 48 mm Depth = 110 mm
Panel Cutting Dimensions	91 +/- 0,5 mm x 46 +/- 0,5 mm
Weight	430 gr

Modular Structure and Connection Diagram

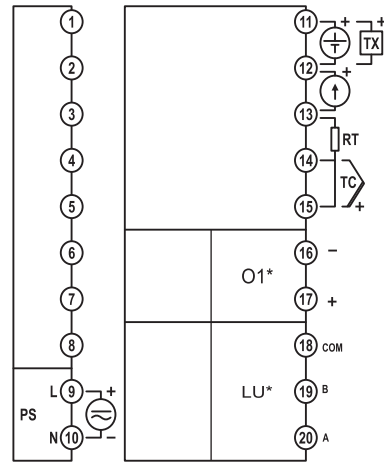

Module	Description
S1	Universal sensor input module (the sensor used to measure process value should be connected to the terminals with appropriate symbol on this module).
S2/O1	0/4-20mA auxiliary analog input or analog output module.*
O1	RS485 Communication Module
PS	Supply voltage input (Supply voltage is determined by product code).

Product Code

