

Advanced Step Control Device



PC941

Device Features

- 2 pcs 4 Digit and 1 pcs 3 Digit Numeric Display
- 6 pcs LED Indicator
- 1 pcs Transmitter Supply Output (24VDC)
- 1 pcs Universal Sensor Input (TC, RT, mA, mV, V)
- 1 pcs Auxiliary Analog Input (0/4-20mA)
- 1 pcs Potentiometer Input
- 2 pcs Numeric Input (15V)
- 1 pcs Analog Output (0/4-20mA, 0/2-10V)
- 1 pcs RS485 Communication Unit
- 4 pcs Relay or Logic Output (24V)
- 100-240V AC/DC Universal or 24V AC/DC Supply Voltage
- Isolation Between Input/Output modules

- 800 Step, 100 Program Step Controls
- Possibility of Relay Positioning Steps
- 7 Different Power-Cut Behaviors
- Control According to Two Input Difference
- Proportional Valve Control With Position Feedback
- Proportional Valve Control Without Feedback
- PID Heating/Cooling
- Auto-Tuning (Automatic settings of PID parameters)
- Programed/Automatic/Manual Working Modes
- Bumpless Transfer Ability
- Sensor Error Detection
- Remote Set Point
- 4 pcs Optional Set point
- Ramp Function
- Retransmission(For process and Set Value)
- 18 Different Relay Functions
- ON/OFF, P, PI, PD, PID Controls
- Linear and Time Proportional Control Output
- 100ms Sampling and Control Cycle
- Standard MODBUS RTU Communication Protocol
- Master-slave and cascade control applications
- Configuration via Computer

PC941 devices are 96 x 48 mm in size. They are designed to measure the temperature, pressure, speed, level, humidity, current, voltage, resistance and other physical units, as well as the on / off and PID control of many process variables in industrial environments. They are completely modular and each module can be configured individually. It is used in Food, Plastic, Iron Steel, Chemistry, Metallurgy, Cement, Ceramic, Petro-Chemistry, Refineries, Glass and other industries. They are ergonomic devices whose compliance with international standards, reliability and ease of use have been ensured at the design stage.

Input Types

Sensor Type	Standard	Min.	Max.
Type-T (Cu-Const)	IEC60584	-200 °C	300 °C
Type-U (Cu-Const)	IEC60584	-200 °C	600 °C
Type-J (Fe-Const)	IEC60584	-200 °C	800 °C
Type-L (Fe-Const)	IEC60584	-200 °C	900 °C
Type-K (NiCr-Ni)	IEC60584	-200 °C	1200 °C
Type-E (Cr-Const)	IEC60584	-200 °C	1200 °C
Type-N (Nicrosil-Nisil)	IEC60584	0 °C	1200 °C
Type-S (Pt%10Rh-Pt)	IEC60584	0 °C	1500 °C
Type-R (Pt%13Rh-Pt)	IEC60584	0 °C	1600 °C
Type-B (Pt%18Rh-Pt)	IEC60584	0 °C	1800 °C
Pt-100	DIN 43760	-200 °C	850 °C
0 / 4-20 mA		0 mA	20 mA
0 / 2-10 VDC		0 VDC	10 VDC

Device Dimensions

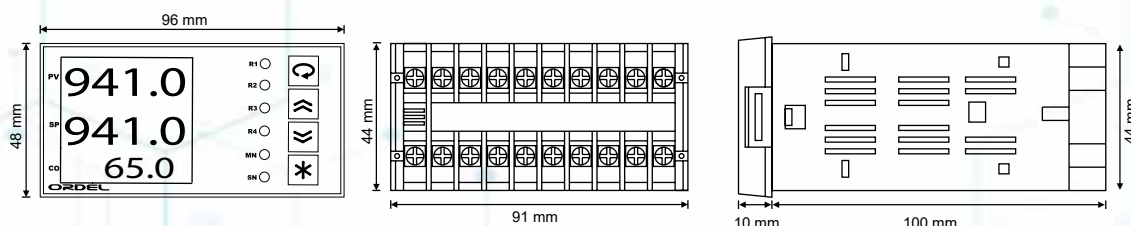

Panel Cutting Dimensions = 91+/-0,5 mm x 46+/-0,5 mm

Technical Specifications

Power Supply (PS)	100-240 Vac/dc +10%-15% 24 Vac/dc +10%-20%
Power Consumption	6W, 10VA
Universal Sensor Input (S1)	Thermocouple = B, E, J, K, L, N, R, S, T, U Two Wired Transmitter = 4-20mA Resistance Thermometer = Pt-100 Current = 0/4-20mA Voltage = 0-5mV, 0/2-10V
Transmitter Supply (TX)	24Vdc (I _{sc} = 30mA)
Analog Input Impedance	Thermocouple, mV = 10MΩ Current = 10Ω Voltage = 1MΩ
Analog Output (O1)	Current = 0/4-20mA (RL≥500Ω) Voltage = 0/2-10V (RL≥1MΩ)
Relay Output (R1,R2,R3,R4)	Contact = 250VAC 10A Logic Output = 24Vdc 20mA
Contact Lifetime	No Load = 10.000.000 Switching 250V, 10A Resistive Load = 1.000.000 Switching
Memory	100 Years, 100.000 Renewals
Accuracy	+/- 0,2%
Sampling Time	100 ms
Environment Temperature	Working = -10...+55°C Storage = -20...+65°C
Protection Class	Front Panel = IP54 Trunk = IP20
Dimensions	Width = 96 mm Height = 48 mm Depth = 110 mm
Panel Cutting Dimensions	91 +/- 0,5 mm x 46 +/- 0,5 mm
Weight	430 gr

Modular Structure and Connection Diagram

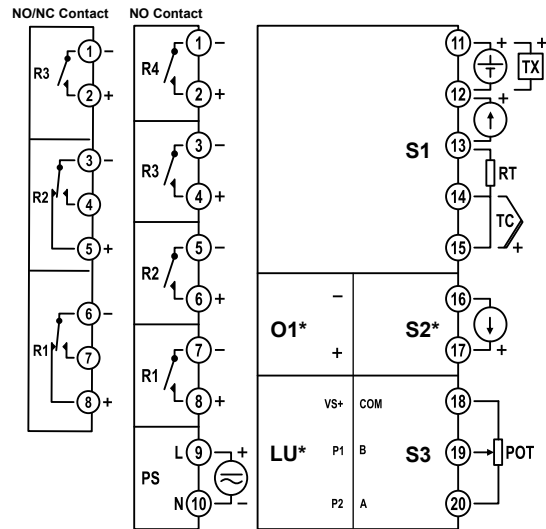

Module	Description
S1	Universal sensor input module (the sensor used to measure process value should be connected to the terminals with appropriate symbol on this module).
S2/O1	0/4-20mA auxiliary analog input or analog output module.*
S3/LU/CU	100-15000Ω potentiometer input (The function of this module can be selected over the device).
R1,R2,R3,R4	Relay output modules (The content of this module is determined by the product code, function is selected from the configuration page).
PS	Supply voltage input (Supply voltage is determined by product code).

Product Code

PC941 - / 0 /

Power Supply :	PS
0 = 100-240Vac (Universal) 1 = 24Vac/dc	
Communication Module :	LU
0 = N/A 1 = 2 Pcs 15V Logic Input 3 = RS485 (MODBUS) Communication Module	
Analog Output Module :	O1
0 = N/A 1 = 0/4-20mA Current Output 2 = 0/2-10V Voltage Output	
R1, R2 Output Modules :	R1-R2
0 = N/A 1 = NO Contact 2 = 24V Logic Output (to drive SSR) 3 = NO/NC Contact	
R3,R4 Output Modules :	R3-R4
0 = N/A 1 = NO Contact 2 = 24V Logic Output (to drive SSR)	

*Note : If R1 relay is coded as 3 (NO / NC), and relay R2 is selected as contact, it must be coded as NO / NC.
If the R2 relay is coded as 3 (NO / NC), and the R1 relay is selected as a contact, it must be coded as NO / NC.
If R1, R2 module is selected as 3, then R4 module must be coded as 0.*