

Standard Step Control Devices



PC48



PC96

PC48 devices are 48 x 96 mm in size. Temperature, pressure, speed, level, humidity, current, voltage, resistance and other physical units of many process variables in industrial environments can be measured. Designed for on / off and PID control, 1 program and 10 steps can be entered. They are fully modular and each module can be configured as self-contained devices.

PC96 devices are 96 x 48 mm in size. Temperature, pressure, speed, level, humidity, current, voltage, resistance and other physical units of many process variables in industrial environments can be measured. Designed for on / off and PID control, 1 program and 10 steps can be entered. They are fully modular and each module can be configured as self-contained devices.

Device Features

- 2 pcs 4 Digit Numeric Indicator
- 6 pcs LED Indicator
- 1 pcs Transmitter Supply Output (24Vdc)
- 1 pcs Universal Sensor Input (TC,RT,mV,V,mA)
- 1 pcs Analog Output (0/4-20mA,0/2-10V)
- 1 pcs RS485 Communication Unit
- 4 pcs Relay or Logic Output (24Vdc)
- 100-240Vac/dc or 24Vac/dc Power Supply
- Isolation between Input/Output Modules

- 10 Step 1 Program Step Control
- 2 Different power-up Behavior
- ON/OFF, P, PI, PID Control Options
- Auto-Tuning
- Sensor Error Detection
- 4 pcs Optional Setpoint
- 9 Different Relay Functions
- Linear and time-proportional control output
- 100ms Sampling and Control Cycle
- Standard MODBUS RTU Communication Protocol
- Configuration via Computer

Device Features

- 2 pcs 4 Digit Numeric Indicator
- 6 pcs LED Indicator
- 1 pcs Transmitter Supply Output (24Vdc)
- 1 pcs Universal Sensor Input (TC,RT,mV,V,mA)
- 1 pcs Analog Output (0/4-20mA,0/2-10V)
- 1 pcs RS485 Communication Unit
- 4 pcs Relay or Logic Output
- 100-240Vac/dc or 24Vac/dc Power Supply
- Isolation between Input/Output Modules

- 10 Step 1 Program Step Control
- 2 Different power-up Behavior
- ON/OFF, P, PI, PID Control Options
- Auto-Tuning
- Sensor Error Detection
- 4 pcs Optional Setpoint
- 9 Different Relay Functions
- Linear and time-proportional control output
- 100ms Sampling and Control Cycle
- Standard MODBUS RTU Communication Protocol
- Configuration via Computer

Technical Specifications

Power Supply (PS)	100-240 Vac/dc +10%-15% 24 Vac/dc +10%-20%
Power Consumption	6W, 10VA
Universal Sensor Input (S1)	Thermocouple = B, E, J, K, L, N, R, S, T, U Two Wired Transmitter = 4-20mA Resistance Thermometer = Pt-100 Current = 0/4-20mA Voltage = 0-5mV, 0/2-10V
Transmitter Supply (TX)	24Vdc (I _{sc} = 30mA)
Analog Input Impedance	Thermocouple, mV = 10MΩ Current = 10Ω Voltage = 1MΩ
Analog Output (O1)	Current = 0/4-20mA (R _L ≥500Ω) Voltage = 0/2-10V (R _L ≥1MΩ)
Relay Output (R1,R2,R3,R4)	Contact = 250VAC 10A Logic Output = 24Vdc 20mA
Contact Lifetime	No Load = 10.000.000 Switching 250V,10A Resistive Load = 1.000.000 Switching
Memory	100 Years, 100.000 Renewals
Accuracy	+/- 0,2%
Sampling Time	100 ms
Environment Temperature	Working = -10...+55°C Storage = -20...+65°C
Protection Class	Front Panel = IP54 Trunk = IP20
Panel Cutting Dimensions	46 +/- 0,5 mm x 91 +/- 0,5 mm 91 +/- 0,5 mm x 46 +/- 0,5 mm
Weight	430 gr

Modular Structure and Connection Diagram

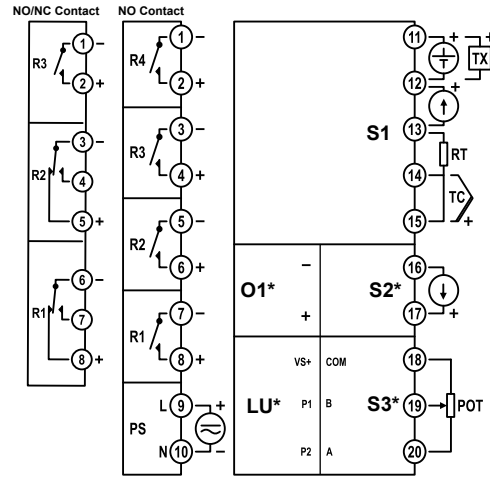

Module	Description
S1	Universal sensor input module (the sensor used to measure process value should be connected to the terminals with appropriate symbol on this module).
S3,LU,CU	RS485 MODBUS RTU
R1,R2,R3,R4	Relay output modules (The content of this module is determined by the product code, function is selected from the configuration page).
PS	Supply voltage input (Supply voltage is determined by product code).

Product Code

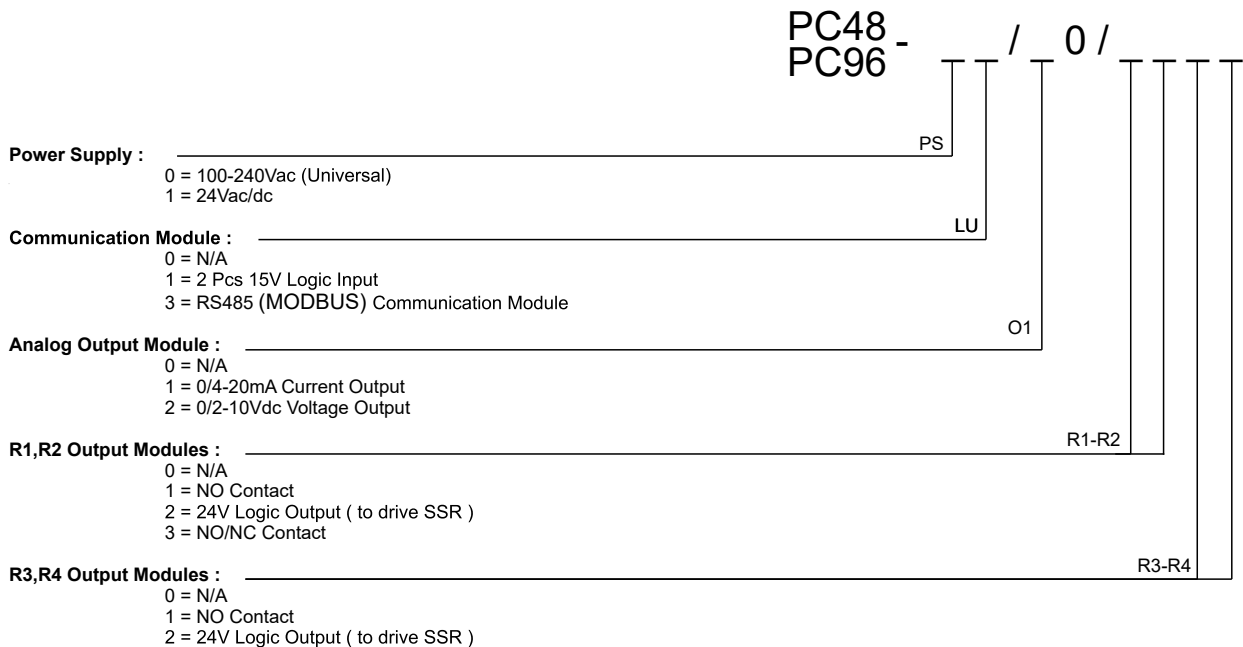

*Note : If R1 relay is coded as 3 (NO / NC), and relay R2 is selected as contact, it must be coded as NO / NC.
If the R2 relay is coded as 3 (NO / NC), and the R1 relay is selected as a contact, it must be coded as NO / NC.
If R1, R2 module is selected as 3, then R4 module must be coded as 0.*